

Short Guide

Information for Traditional Building Owners

Sash & Case Windows

A short guide
for homeowners



Maintaining your sash and case windows



An early sash and case window with thick astragals



Early 19th Century lying panes



A fine example of 19th Century curved sash frames and glass

In the late seventeenth century, pulleys and weights were first applied to timber sashes and the vertical sliding sash and case window was born. The new style of window soon caught on and they were installed throughout Scotland in the 1680s and 1690s. These very early windows have chunky timber members subdividing sashes into very small panes to suit the limited size of poor quality glass which was available.

In the eighteenth century, larger pane sizes and slimmer sash members became feasible. By the middle of the century the familiar Georgian window with 6 panes to each sash had become commonplace. Better quality crown glass was used to glaze these windows, recognisable by its distinctive curved ripples and the slight bellied effect often visible in individual panes when viewed in sunlight. True crown glass is no longer made, making it all the more important to keep any historic crown glass found.

In the early nineteenth century, whilst the Georgian pattern continued to be used, horizontally proportioned panes called lying panes were also popular. Occasionally margin panes were used in buildings of this period, an arrangement which continued to be used for stair windows long afterwards.

Cylinder sheet and patent plate glass began to be used instead of crown glass. These glass types are characterised by straight ripples and by occasional 'seeds' or bubbles in the glass. From the middle of the century onwards fewer subdivisions and larger, heavier panes of glass became common. Eventually sashes were glazed with single large panes of plate glass. Sash frames and joints were strengthened to suit – occasionally incorporating projecting horns. As large panes became fashionable, old sashes with multiple small panes were sometimes altered – their glazing bars were removed and they were reglazed with larger panes of plate glass.

At the end of the nineteenth century and beginning of the twentieth century, as a reaction to the trend towards ever-larger panes, small paned sash windows, sometimes with chunky glazing bars, became briefly popular again. Often windows of this period combine a multiple paned upper sash – very often with horns – with a single or 2 pane lower sash. Upper sashes from this period sometimes incorporate stained glass – a feature that was to remain in vogue into the 1930s.

After reigning supreme in all types of buildings from castle to croft for two and a half centuries, the sash and case window finally fell out of widespread use in new buildings in Scotland in the 1950s.



A Georgian sash and case window



As glass-making technology advanced, the number of subdivisions of the frame became common.



19th Century windows with margin panes



Late 19th Century window

The component parts of the sash and case window

A typical sash and case window, including the terms used to describe parts of the window in this leaflet.

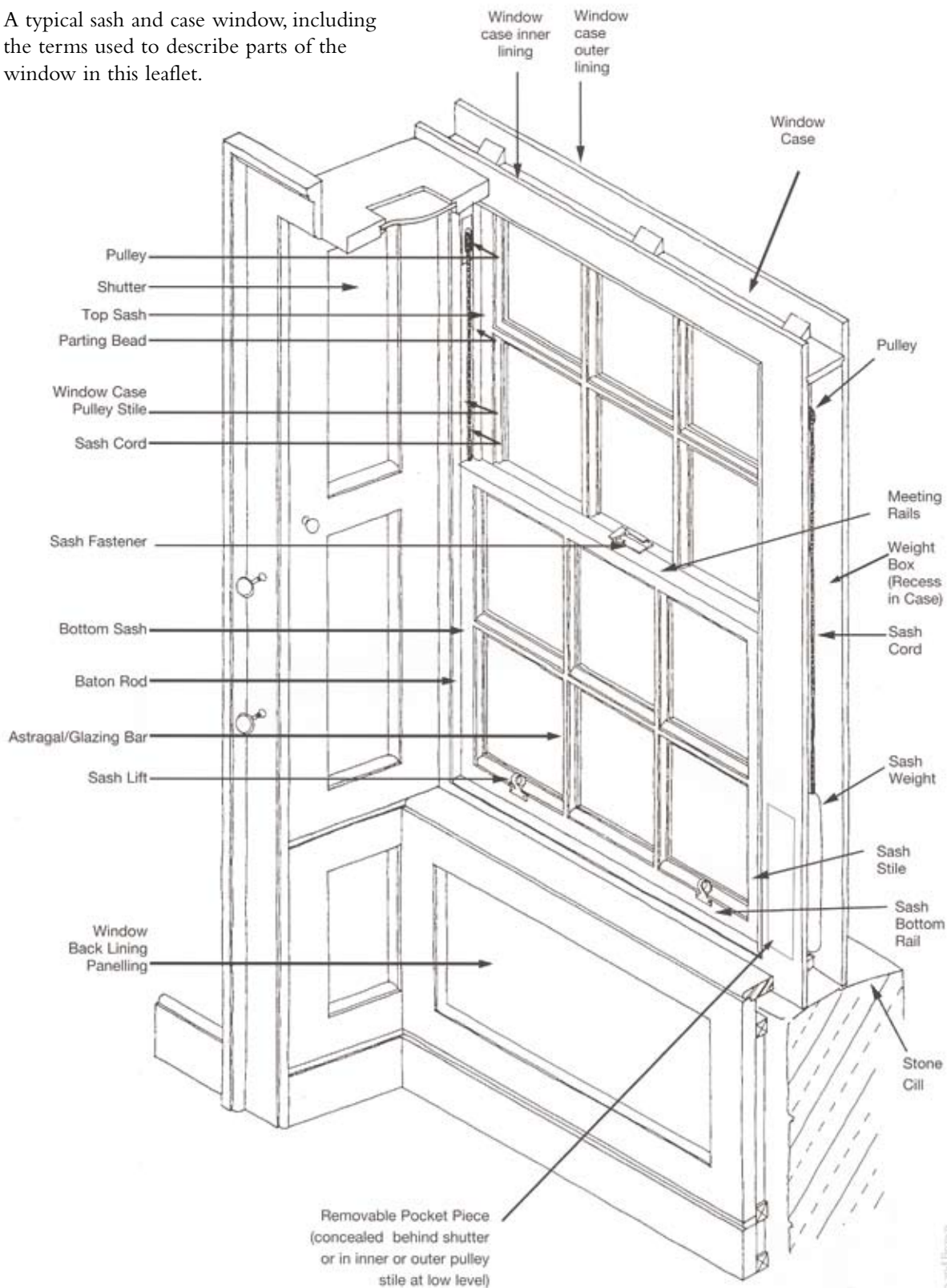

Simpson and Brown

Maintaining your sash and case windows

Timber sash and case windows are essentially of straightforward design and construction and are readily maintained and repaired. Given sensible maintenance at regular intervals, sash and case windows should remain in good condition and will be capable of providing continuing efficient service.

Prior to undertaking any maintenance work on your windows please refer to the health and safety guidance on page 12.

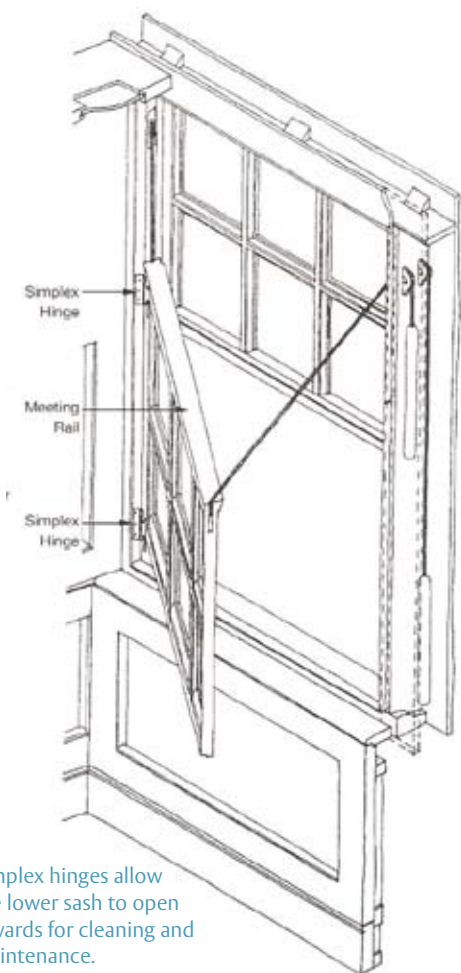

Simplex hinges allow the lower sash to open inwards for cleaning and maintenance.

Cleaning

Regular cleaning of glass and timber surfaces will improve the appearance of sash windows and ensure they function correctly.

It is important to be aware of your own safety when cleaning windows – keep both feet firmly on the ground (no chairs or stools) and do not over-reach.

The upper sash should be drawn down to a comfortable height – it will then be easy to clean the inner face. The outer face should be cleaned with extreme care – bearing in mind the guidelines given below.

The lower sashes of many traditional sash and case windows are fitted with the ‘Simplex’ hinge system. If so, then both inner and outer faces of the sash can be cleaned from within the building. If not fitted, you should consider installing Simplex hinges to make cleaning easier.

Cleaning also presents an opportunity to inspect windows regularly. This will enable you to keep abreast of any developing defects so that corrective action can be taken before they can progress into more major problems.



The Simplex hinge system in operation

Diagrams showing how sash and case windows may be safely cleaned, following guidelines in BS8213

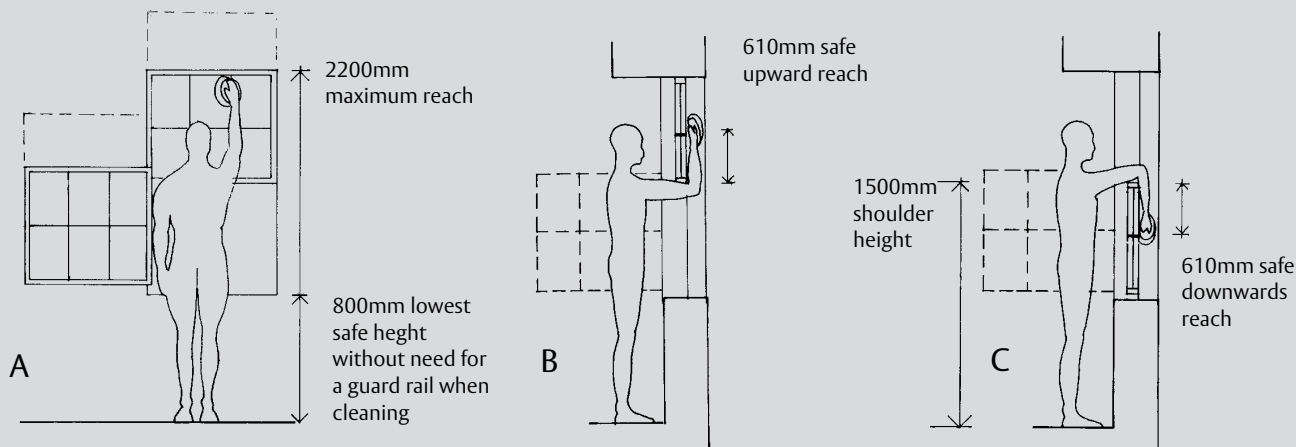

The lower sash is swung inwards on Simplex hinges so that its outside face can be cleaned. With the lower sash swung in, the top sash is moved down so that all of its inside face can be reached (A). The top sash's position is then adjusted so that the lower part of its outside face can be cleaned (B) and then fully dropped to enable the remaining upper part of the top sash's outside face to be cleaned (C).

Maintaining your sash and case windows

Painting

Paintwork to the external faces of windows must be maintained in good condition to protect joinery and putty from the elements. Windows normally require external repainting every 5 years depending upon exposure. Redecorating windows in good time, before paintwork has begun to break down, will minimise preparation requirements.

The following general principles apply:

- prepare existing surfaces.
- apply treatment to knots and resinous patches and prime any bare wood.
- ensure each layer is applied onto a perfectly dry, clean and sound surface.
- ensure that the putty is completely covered and the glass to putty joint is sealed with paint, but avoid spreading the paint too far onto the glass surface and maintain a straight sight line.

In certain instances Local Authority planning controls may apply to your property covering acceptable paint colours for external joinery. See 'What controls apply to works to windows?' section on page 10 for more details.

A number of different paint systems are available – usually with different specifications for external and internal use. For external use an appropriate gloss paint or microporous paint specification is required. Manufacturers' recommendations as to suitability and use of primers, 'knotting' treatments and the numbers of undercoats and finish coats required should be followed.

Preparation for painting

Surfaces must be prepared for repainting. Where existing paint is generally sound, all that may be required is gentle use of sandpaper to provide a key, followed by washing down with sugar soap or washing up liquid in water to remove dirt and grease. Loose and flaking defective paint

should be removed using sandpaper and a thin bladed scraper, taking care not to damage the underlying timber. Sash lifts and other fittings can be removed if required but the sash fastener should be left in place if it is in good condition, as later realignment is often difficult.

When considering paint removal it should be borne in mind that the layers of paint surviving on window joinery are a record of the decorative history of the building, which would be entirely lost by stripping. Where complete stripping of a listed building's windows is unavoidable, it is suggested that a small area of paint on the internal and external faces of the top right hand corner of the top sash, together with a small area on the case is retained for record purposes. The edges of these patches can be sanded smooth prior to over painting so that they are not visible. A record of their location should be maintained.

Caution should be exercised when stripping paint to avoid damage to timber, glass, putty and surrounding masonry. Alternative methods of paint removal are as follows:

Chemical Paint Strippers

Use of aggressive caustic strippers by hand application or 'dipping' is not recommended. More suitable and less aggressive chemical paint removers for hand application (for example dichloromethane and methanol solvent based products) are readily available from trade and DIY retailers.

Mechanical Sanding and Scraping

Care should be exercised using scrapers and when sanding to avoid gouging timber surfaces and eroding moulding details.

Heat

Use of a gas fuelled blowtorch is not recommended. Gentle heat from a hot air gun can be effective but glass must be protected by a shaped metal heat sink shield – and extreme care must be exercised as glass is liable to crack even under this gentle heat.

Occasionally localised or complete paint removal back to bare timber may be necessary:

- where windows have been badly neglected and paint has broken down
- where paint has been poorly applied in the past and the finish is rough and unsightly
- where paint is thickly built up to the stage where mouldings are obscured
- where the smooth running of the sashes is interfered with by multiple coats of paint.

Painting windows in-situ

- ❑ pull the top sash right down, push the bottom sash up past it.
- ❑ paint three sides of the top and bottom meeting rails, the lower half of the stiles and glazing bars, and the parts of the lower sash you can reach.
- ❑ paint the inner cill and the lowest 75mm only of the pulley stiles).
- ❑ let the paint dry.
- ❑ swap the position of the sashes, i.e. bottom sash right down and top sash half way up.
- ❑ paint the remaining parts of both sashes.
- ❑ paint the top half of the pulley stiles.
- ❑ DO NOT paint the parts of the pulley stiles that are hidden by the sashes when they are closed.
- ❑ let the paint dry.
- ❑ paint the surrounding woodwork.

Usually window sashes can be satisfactorily prepared and repainted in situ. However where extensive preparation and thorough repainting is required sashes can be taken out for these works comparatively easily – as described in the ‘Re-cording’ section.



The sash weight can be seen here where the pocket piece has been removed to expose the interior of the window case.

Re-cording

The majority of window sashes are counterweighted so that they can be operated easily. Sashes are hung on cords which pass over pulleys and connect to weights concealed within the weight boxes in the hollow sides of the case. These cords require replacement when worn or broken. In larger heavier windows, chains were often used instead of cords and should be retained and refurbished as necessary.

Cord replacement requires the sashes to be removed from the frame and is a two person job best carried out by joiners as follows:

- ❑ one of the inner baton rods is removed. This will be secured by secret nailing, screws or with turnbuckles or other easy-to-use fittings if Simplex hinges are fitted.
- ❑ if the cord for the top sash is being replaced, the parting bead on the same side as the removed baton rod is also prised out to allow the sash to be released.
- ❑ cords are detached from the side of the sash using a tack lifter and the sash is set aside. Beforehand, temporary support must be provided to avoid either the sash dropping or the cord and the concealed weight to which it is attached dropping within the case which could cause damage.
- ❑ the weight box ‘pocket piece’ cover adjacent to the damaged rope is removed to give access for retrieving the sash weight from the bottom of the case and to allow clearing out of any accumulated debris from inside the weight box.
- ❑ The new sash cord must be of the same diameter as the old to avoid snagging on the pulley. Cotton cord is normally supplied pre-stretched and impregnated with wax to reduce the risk of rot and to allow it to run smoothly. Braided cord is preferable to twisted as it is more durable.
- ❑ A generously over-length section of the new sash cord is threaded over the pulley and down into the weight box until it is visible at the bottom and is tied to the existing weight.
- ❑ The length of the sash cord hanging over the pulley is adjusted so that the sash weight hangs 75 – 100mm clear of the bottom of the weight box when the sash to which it is connected is fully raised. This clearance reduces knocking noises during operation and also allows for any stretching that may occur during the life of the cord.
- ❑ The sash is temporarily supported close to the window opening and the new cord is pulled down slack, set into the groove in the side of the sash, and gently nailed into position using large blued tacks.
- ❑ Once both sash cords are attached, the sash is manoeuvred into position and checked for satisfactory operation prior to refixing the parting bead and baton rod back in position.

Repairing sash and case windows

Repairing

Straightforward design and construction of timber sections means that sash and case windows can be repaired readily – even the most dilapidated windows are usually capable of resurrection.

Most old sash and case windows were manufactured from exceptionally durable heartwood timber of a quality now difficult to obtain. It therefore makes sense to retain and repair original joinery rather than replacing wholesale with new timber which may be more susceptible to decay.

Agreeing the amount of work and price with your joiner

It is unlikely that you will be carrying out repairs to windows yourself. But it is suggested that you do some preparatory assessment work before employing a joiner to do the work for you so that you can agree how much work is required and what the price should be. An inspection checklist, together with a comprehensive guide to specifying repairs for all common defects, is included as a pull-out section at the back of this leaflet. By using this checklist and following the method of assessing your windows given in the adjacent text on this page you will be able to make a note of what defects are present in your windows.

If you wish, you can then use the comprehensive guidance provided to prepare a list of suggested repairs for each window to discuss with your joiner. Alternatively, you can just hand the guide to specifying repairs and your completed basic survey checklists for all your windows to your joiner as the basis on which to price and carry out the work.

Assessing your windows

You will have to look carefully at each of your windows in turn to determine the extent of any defects requiring repair.

Preparation:

- Make enough photocopies of the checklist from the pull out section at the back of this leaflet so that you have one copy for each of your windows.
- Assess any risks involved (e.g. difficulty of access, loose, damaged or broken glass, hinges or sash cords).

The following tools may be required:

- penknife: for testing timber for decay and to loosen seized sashes.
- wood chisel: for loosening seized sashes (use with care to avoid damage).
- craft knife: for cutting through paint layers if windows have been painted shut.
- screwdriver: to free sash locks, screw-fixed baton rods and to open weight box covers.

Inspection:

- Go through the checklist systematically for each window and note any defects on the sheet. It should not be assumed that because you can see a problem in one window they are all affected.
- Most defects will be recognised on close visual inspection, but this may not be sufficient in the case of timber decay. If decay is suspected, test the timber with the blade of a penknife – sound timber will resist penetration.
- Open sash fasteners and any other locking devices and operate both sashes, sliding for full length of travel in each case. Note any stiffness or resistance, as well as any tendency of sashes to drop out of control of the counterbalancing weights.
- If you are unable to move either upper or lower sash, check for signs that paint is sticking sashes together or to the surrounding joinery.
- Undo and remove, or rotate clear, the baton rod if fixed by turnbuckles or screws only (ie do not attempt if the baton rod is secured by nails).
- Hinge in lower sash on Simplex hinges if they are fitted.
- Open weight box pocket piece covers to examine type and condition of weights, and ensure box is clear of debris that might accumulate. A musty smell indicates the presence of damp and the potential for timber decay.
- Check operation of shutters (if any). Look behind shutters for signs of dampness in plaster or wood-rot in the window case.

Some repair techniques



Pieced in section of timber to stile

Note the grain density and direction of original and new timber in photo. Replacement timber should be selected to match the existing timber as closely as possible - otherwise the new and old timbers may shrink and expand at different rates causing gaps to open up in otherwise sound repairs.

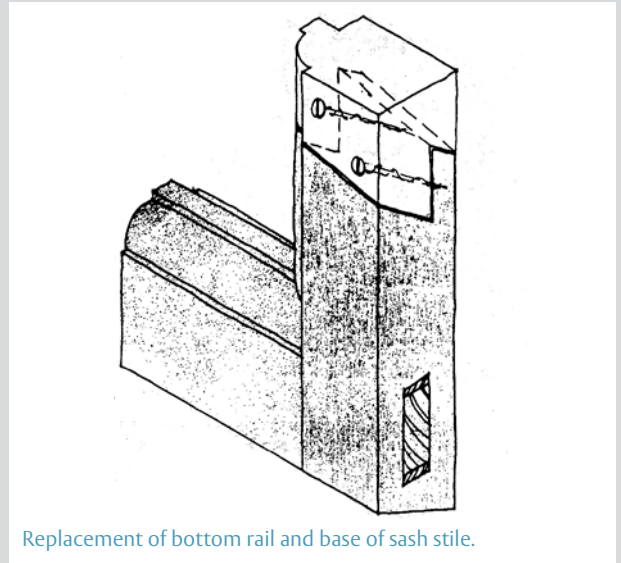

Replacement of bottom rail and base of sash stile.

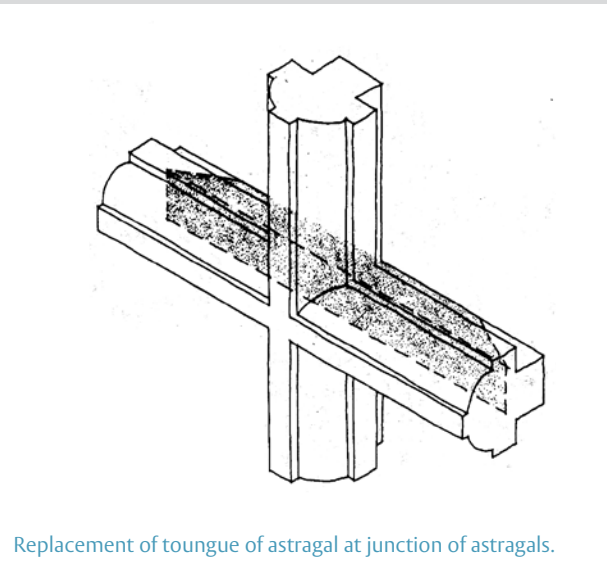

Replacement of tongue of astragal at junction of astragals.

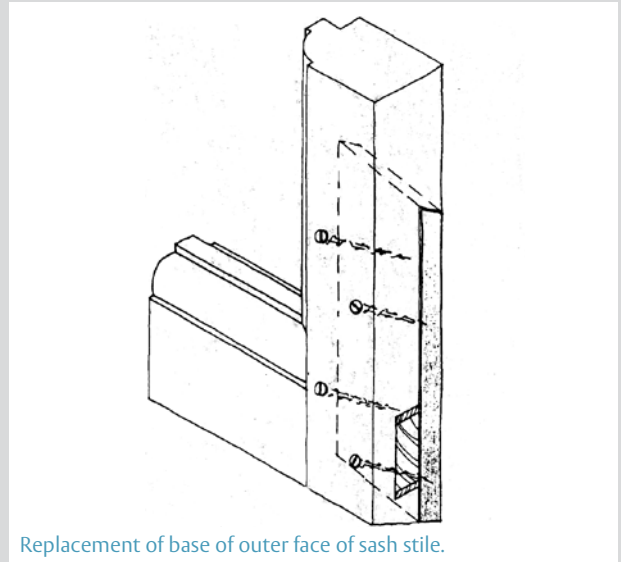

Replacement of base of outer face of sash stile.

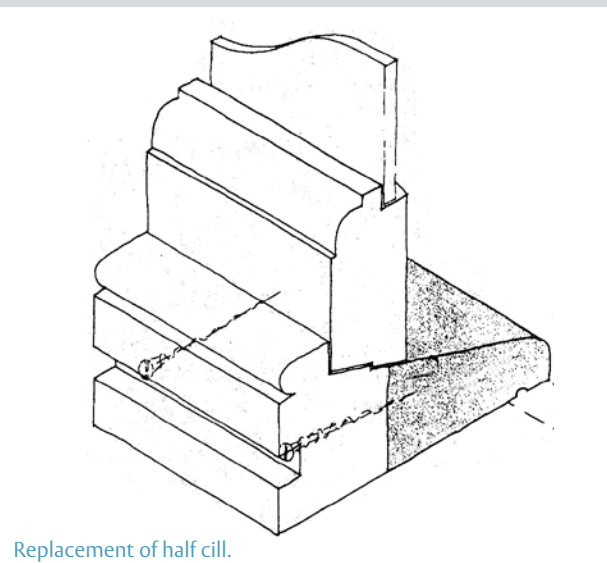

Replacement of half cill.

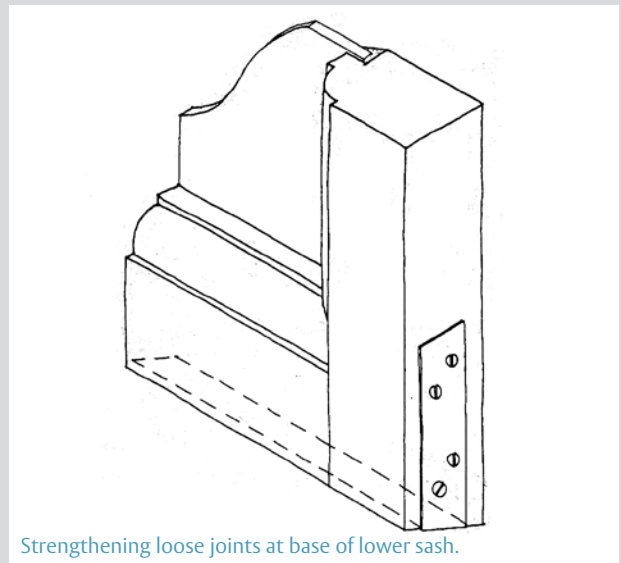

Strengthening loose joints at base of lower sash.

Upgrading sash and case windows

Double-glazing

Replacing existing timber windows with new, double glazed windows is often promoted as a means of combating heat loss, draughts, dust ingress and providing perceived improvements to sound insulation and security. However research has shown that double glazed replacement of existing windows is not cost effective in comparison with other energy conservation measures. In fact your existing windows can be upgraded at a lower cost to bring these benefits whilst still retaining the original features and style which give character to your home.

The replacement of the panes of glass in existing multi paned sashes with double glazed units is usually not possible. This is due to the narrow astragal and small glazing rebate dimensions of existing windows being incompatible with the technical requirements of double glazed units, which usually require a much larger rebate and a corresponding enlargement of astragal size.

As an alternative, secondary glazing, using side hung or horizontally or vertically sliding windows, can be fitted internally. Secondary glazing reduces heat loss and dust ingress and provides very good insulation against noise. Where the building is listed, this alteration would require consent from your Local Authority planning department.

Draught-stripping

Draught-stripping can be fitted cheaply and unobtrusively to timber sash and case windows to bring them up to modern performance standards. Several proprietary systems are available. It is a cost effective way of improving comfort and noise insulation and reducing heat loss and dust ingress. Some of the proprietary draught-stripping systems also make the window easier to slide up and down.

Where the building is listed, further advice should be obtained from your Local Authority Planning Department as to the suitability of the draught-stripping proposals for historic windows.

Ventilation

As both sash positions can be widely adjusted – from a small gap to fully open – sash and case windows allow gentle and beneficial ventilation to suit most weather conditions.

Fitting proprietary trickle vents into slots cut in the rails of window sashes is not recommended as joinery sections are likely to be significantly weakened and the ventilator units can look obtrusive.

Where additional closable background trickle ventilation is required, the following alternative methods should be considered:

- ❑ chamfer the outside edge of the head of the top sash and insert an adjustable grille into the head of the window case on the inside and a fixed grille on the outside to allow ventilation over the top of the window. (see diagram opposite)
- ❑ insert a permanent grille in the external pulley stile and an adjustable grille in the inner pulley stile to allow ventilation through the weight box. (see photo opposite)

Where permanent ventilation is required to provide combustion air for open fires and gas appliances, it is usually preferable to provide an air supply grille close to the appliance (from a ventilated floor void for instance) to avoid draughts. However, if use of windows as a combustion air source is unavoidable, any of the above methods can be used – substituting a fixed ventilator for the closable ventilator. A simpler option is to:

- ❑ block down the top sash and sash fastener so that a suitable gap is maintained above the top sash and at the meeting rails even when the window is closed and fastened.

The ‘free area’ of these permanent ventilation openings for combustion air must comply with the requirements of the Technical Standards (building regulations) and appliance manufacturer’s recommendations.

Where the building is listed, further advice should be obtained from your Local Authority Planning Department as to the acceptability of providing additional ventilation by these methods.

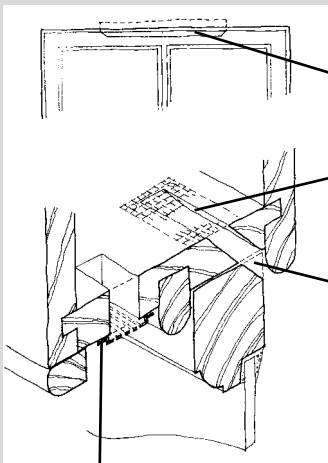

Chamfered termination to slot in top sash

Insect mesh fixed

Neatly formed slot cut diagonally from outer face of top sash and through case (centred over half of top rail)

Slots cut through case inside, with proprietary trickle vent hit-and-miss grille

Method of providing background ventilation over window head

method of providing permanent ventilation by blocking down top sash

Allows ventilation through resulting gap between meeting rails even when window is closed

method of providing background ventilation through window pulley stiles

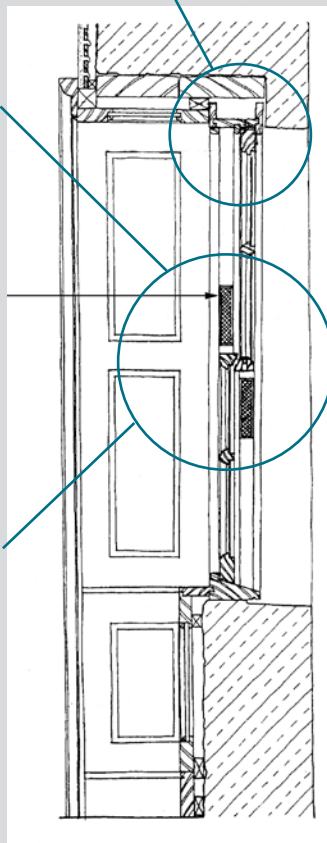

Slots cut in both the inner and outer section of the pulley stile and insect mesh and grilles fitted.

Ironmongery, security and safety

Surviving original ironmongery fittings such as sash lifts, sash fasteners and hooks are usually of a very high quality and should be retained where possible. Where such ironmongery has been obscured by thick over-painting, it can usually be cleaned without difficulty and restored to its original appearance. Repair of damaged items is also possible. Reproduction fittings are available where original ironmongery is missing or damaged beyond repair.

Additional sash locks can be fitted to the meeting rails to improve the security of the window when closed. Timber blocks and / or special items of ironmongery called 'sash stops' can also be fitted to restrict opening beyond the required point thus allowing ventilation and cleaning access, whilst preventing illegal entry and safeguarding against accidental falls. Where windows have very low cills, internal barriers can be fitted to help prevent accidents and to achieve compliance with Technical Standards (building regulations) where applicable.

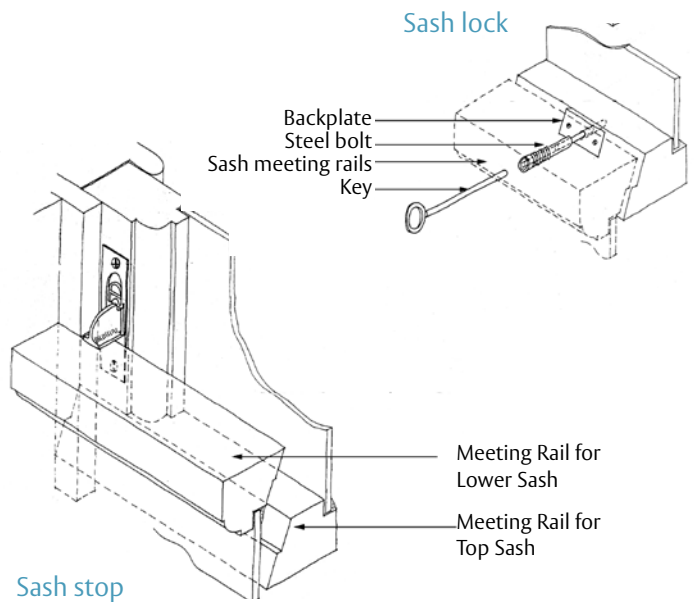

Sash stop

Traditional Remedies

Do not forget the existing features of your windows and traditional solutions that you can use to improve performance:

- closing and securing shutters, where fitted, can provide extra security
- closing shutters can also provide privacy and reduce heat loss at night-time
- heavy lined curtains can significantly reduce draughts and heat loss when drawn

What controls apply to works to windows?

Your home may be a listed building – included for its special architectural or historic interest on the list compiled on behalf of the Scottish Ministers.

Proposals to undertake any work which may change the appearance of windows in listed buildings will be subject to listed building control and will require listed building consent (LBC).

Works requiring LBC include proposed changes of frame material or change to operating method; changes of timber astragal (glazing bar) profile or the arrangement of panes; change of glazing panes to double glazed units and changes to paint colour or finish. Installation of secondary glazing or provision of special ventilation arrangements is also likely to require LBC.

Your home may be unlisted but situated in a conservation area designated by your Local Authority (LA) where there are planning controls over window alterations. Your LA may also have planning policies controlling alterations to windows in other locations such as flatted properties or properties along important routes. These LA controls may also include acceptable paint colours for external joinery.

Prior to carrying out any works, contact your LA Planning Department which will be able to tell you if your house is listed, in a conservation area or subject to any other controls affecting works to windows. Any works you propose to undertake should also be discussed with them first to determine whether any formal consents or permissions are required.



Replacing traditional sash and case windows changes the character and appearance of a building.

Grants

Grants may be available towards the cost of repairing and upgrading historic windows. Guidance can be obtained from your Local Authority (LA) Planning Department in the first instance. Where an area has been designated a conservation area and classified as outstanding for the purposes of grant, a number of LAs have set up Town Schemes. These schemes are jointly funded by the respective LA and Historic Scotland and provide grants to assist with modest schemes of repair to building elements such as sash and case windows. Your LA will be able to advise whether a Town Scheme has been set up in your area or whether there are plans to do so.

Historic Scotland also administers a major programme of building repair grants throughout Scotland for buildings of outstanding architectural or historic importance, or key buildings within outstanding conservation areas. If your building is in need of major repairs you may be eligible to apply. For further information and advice telephone 0131 668 8801 or e-mail to hs.grants@scotland.gsi.gov.uk.



Selection of specialist contractors and suppliers

Historic Scotland's Technical Conservation Group maintains a list of joinery contractors, specialists and suppliers. For further information and advice telephone 0131 668 8668 or e-mail to hs.technicalconservationgroup@scotland.gsi.gov.uk.

If you do not know a contractor's work personally, ask them to give you references for a number of their recent projects. It is advisable to visit these projects and/or to speak to the building owners to confirm that the results of the works have been satisfactory.



Health and safety considerations

During inspection, maintenance and repair works a number of precautions should be observed. Care should be taken to avoid the risk of falling out when working at upper floor windows. Any steps used to reach high level parts of the windows should be stable. Old glass is often very thin and fragile. Special care should therefore be exercised when working to avoid breakage and the risk of injury.

Old paint on joinery is likely to contain lead. Therefore, when carrying out sanding and stripping operations, manufacturers' health and safety guidelines should be followed to deal with this and other more general hazards presented by dust and hazardous chemicals. Precautions recommended usually involve working in well ventilated areas, using only wet abrasive techniques when sanding, wearing appropriate masks and gloves and avoiding eating, drinking or smoking in the work area.



Sash and Case Window Inspection Checklist

Window No.	Date	Your name	
Condition of window			
Defect	Tick if present	Notes – add any extra information eg precise location, severity of defect	
Visible defects:			
Visible gap at cill			
Gaps leading to draughts			
Meeting rails not level			
Joints in sashes opening up			
Broken sash cords			
Broken or cracked glass			
Flaking or missing paint			
Timber missing or damaged			
Worn sides to sashes			
Evidence of previous repairs, including metal strengthening angles			
Missing or defective glazing putty			
Missing or defective external mastic at junctions between window and wall			
Missing or defective cill bedding mortar			
Hidden defects:			
Sash(es) drop or rise of their own accord when left unfastened or 'drift' out of position when open.			
Timber decay in cill			
Timber decay in parting beads			
Timber decay in sash frame			
Timber decay in hidden parts of case joinery			
Debris in weight pockets			
Other defects:			
Shutters will not open			
Shutters open with difficulty			
Split panels to shutters or lining			
Timber decay to shutters or lining			
Damp plaster in window recess or behind shutters			
Structural opening defects or distortion			
<p>General Comments <i>Note any extra information you consider relevant eg timber profiles, type of ironmongery, type of glass, type of sash cord etc.</i></p>			

Guide to specifying repairs

The following table relates the defects that you may have identified during inspection to their probable causes and to the suggested repair to remedy them.

Defect	Probable cause	Suggested repair
Visible defects:		
Visible gap at cill	Twisted outer case or weights being prevented from performing full travel in weight box	Check and free snagged weights. Remove lower sash and piece in additional timber to bottom rail
Gaps leading to draughts		Consider installation of draughtstripping (see upgrading section that follows)
Meeting rails not level	Twisted, warped or excessively worn sashes	Check and replace sash cords. Remove both sashes and piece in new timbers to each side to square up sashes
Joints in sashes opening up, showing through paint finish	Mortices snapped or being eased apart, due to excessive force in use	Glue, wedge and clamp the joint. Or strengthen sash by adding non ferrous metal angle plates across corners. Or take out glass from sash; take apart the sash frame members (identify any wedges or dowels and remove these before carefully easing apart the sash rails and stiles by gentle tapping with a hammer against a wood block placed inside the frame near to the joints; any glued joints can be released by the application of steam) and piece in new timbers at ends with new mortices and/or tenons. Old loose dowels should be carefully driven out and new dowels glued into place
Broken sash cords	Wear and tear in old cords. If new cords broken may be due to under-sizing of cord for heavy sashes, or cord snagging on pulley wheel	Take out sashes and weigh them to ensure correct weights. Replace weights or amend as necessary. Renew sash cord. Check sash pulleys free from defects
Broken or cracked glass	External accidental damage or vandalism. Small diagonal cracks in corners often indicate distortion in sash frame	Small corner cracks in original valuable glass will probably be acceptable. For more serious breaks, remove broken glass without damaging timbers and re-glaze as necessary
Flaking or missing paint	Deterioration of old paint system, or may indicate excess moisture levels in under-lying timber	Check moisture levels in timber and correct associated defects. Remove loose paint layers back to a sound base, prepare and re-paint windows using an appropriate paint system
Badly worn and grooved sash stile timber allowing sash to move too freely	Wear and tear erosion of surface as sash is slid up and down – aggravated by projecting lumps and bumps on running surfaces and often by contact with projecting simplex hinges knuckles	Scrape and sand back any projecting timber or paint build up on the surfaces of the pulley stiles, parting beads and batten rods to ensure running surfaces are smooth. Adjust simplex hinge positions knuckles so that they do not project. Move baton rods closer to sash to reduce lateral movement. Make good grooves in sash with a proprietary filler. Where wear is very severe, sashes may require to be re-edged
Timber missing or damaged from any member	May be due to localised decay (e.g. in cills), but elsewhere is likely to be as a result of physical impact damage (e.g. external part of glazing bars split due to careless removal of old putty from the glazing bar check)	Piece in new timber. Decayed timber should be cut out (first removing glass if necessary), and replaced with matching sections. For glazing bar repairs, piecing in missing part is unlikely to be successful over anything other than a short length. In which case, full bar should be replaced
Evidence of previous repairs, including metal strengthening angles	Often metal angles are used to secure broken mortice joints in sashes	No work may be necessary. Metal angles may continue to perform their function. If necessary replace by re-making mortices as described above as the final suggested repair for 'Joints in sashes opening up'

Defect	Probable cause	Suggested repair
Missing or defective glazing putty	Deterioration due to ageing process or where, following repairs, putty has not been re-painted correctly	Cut out defective putty. (You may first have to soften the putty to avoid damaging the surrounding timber or the glass. Putty can be softened using an alkali paint stripper or, with careful use to avoid cracking the glass, a hot-air gun.) Apply a coat of linseed oil thinned with turpentine to the exposed timber before applying new linseed oil putty (this is to reduce the possibility of the wood drawing the oil binder out of the putty). New putty should not be painted until 28 days after it has been installed
Missing or defective external mastic or other sealant between window case joinery and wall	Deterioration due to ageing process or where actual movement in either case joinery or masonry has caused mastic to fail. Applying paint to mastic can accelerate loss of its flexing properties	Cut out defective mastic. Ensure adequate packing of any excessive gap between frame and masonry wall, using suitable packing material. (Dampened, rolled newspaper has traditionally served well, but modern expanding foams have also been successfully used). Use lime mortar to seal over the packing material and finish with a fillet of burnt sand and boiled linseed oil mastic in front to waterproof the joint
Missing or defective cill bedding mortar	Deterioration of (lime) mortar bedding from external sources such as driven rain or other concentrations of water (e.g. from overflowing rhones)	Rake out defective material, place replacement bedding mortar, thoroughly packing it to the full depth of the cill. Rake back to form a recessed drip below the front edge of the cill
Hidden defects:		
Sash(es) drop or rise of their own accord when left unfastened or 'drift' out of position when open.	Sash weights may be too light or too heavy to counterbalance sash. Heavier or lighter glass than originally fitted may have been used in reglazing	Take out sashes and weigh them and the weights. Weights for the upper sash should normally be 2lb (0.9kg) heavier than the sash. Weights for the lower sash should normally be 2lb (0.9kg) lighter than the sash. Replace weights or add extra to existing weights as necessary. Renew sash cord – consider need to upgrade capacity. Check sash pulleys are free from defects
Timber decay in cill	External weathering accelerated if lack of paint finish, or where timber comes in direct contact with masonry	Replacement of either the front part or whole cill using new matching timber can be done with the window in situ.
Timber decay in parting beads	External weathering. Water running down face of window glazing is often concentrated here by being driven by the wind	Routing tools will be needed to form proper joints in the case Parting beads are often best replaced in their entire length. The lower sash will have to be removed while this is done
Timber decay in sash joinery, commonly at lower rails and mortice joints of upper or lower sashes	External weathering, as above, or frequently due to excess internal condensation gathering on horizontal frame members	Replace missing mortices as described above as the final suggested repair for 'Joints in sashes opening up'
Timber decay in hidden parts of case joinery	External weathering, as above, or due to more distant outbreak finding an environment, within the weight pocket, which encourages the development of the rot	Remedy sources of moisture ingress. Ventilate the affected area as much as possible, by opening shutters and weight pockets, carefully setting aside any removed ingo linings. Chemical treatments are rarely necessary on dense pine or oak window joinery
Debris in weight pockets	Commonly due to gradual erosion of mortar or soft sandstones within the core of the wall	Locate and remove weight box 'pocket piece' cover and clear debris before replacing cover

Defect	Probable cause	Suggested repair
Other defects:		
Shutters will not open	Shutters may simply be stuck with layers of paint, or nailed shut	Carefully prise open shutters, removing any fixings. Remove excess paint
Shutters open with difficulty	Hinges on shutters may be damaged or require overhauling. Frequently shutters with back flaps suffer from distortion, causing parts to catch on the surrounding joinery during operation. This could also be caused by distortion of the structural opening, de-pressing the soffit linings and causing the shutter to snag (see 'Structural opening defects' below)	Take off and set aside shutters, check dimensions. Rectify external causes of deflection where possible. Reinstall shutters, 'easing' as required
Split panels to shutters or panelled lining	May be due to changes in moisture levels in timber	Fill very wide cracks with slivers of timber and sand smooth. Normal cracks should be filled with filler prior to redecoration
Timber decay to shutters or panelled lining	Likely to be the result of some external building defect, or of a change of internal environmental conditions	Remedy external sources of moisture. Carefully dismantle and set aside decayed components. Check window case joinery is sound before repairing and reinstating linings
Damp plaster in window recess or behind shutters	Lack of ventilation can cause minor efflorescence on plaster, but more significant moisture is likely to be the result of some external building defect, or of a change of internal environmental conditions	Remedy external sources of moisture. Remove defective plaster. Ensure adjacent timbers are dry, and fixings securing window are sound before replacing plaster
Structural opening defects or distortion	There may be evidence of historic movement, due to settlement or changes in ground or support conditions, but recent movement may be due to ongoing problems, such as decaying timber safe lintels	Employ an engineer to investigate causes of deflection, using non-destructive techniques where possible. Once any structural defect is remedied, window case joinery should be set plumb, level and square in openings to ensure that sashes can operate correctly



HISTORIC SCOTLAND

Published by

Technical Conservation Group,

Decemer 2008

Historic Scotland, Longmore House, Salisbury Place, Edinburgh EH9 1SH

Tel: 0131 668 8600 Fax: 0131 668 8669

Technical Enquiry Service: 0131 668 8668

Publications: 0131 668 8638

www.historic-scotland.gov.uk

email: hs.technicalconservationgroup@scotland.gsi.gov.uk

© Crown copyright

ISBN 978 1 904966 57 9